

Safetygram-12

Regulator Selection, Installation, and Operation

The primary function of a regulator is to reduce high-pressure gas in a cylinder or process line to a lower, usable level as it passes from the cylinder to a piece of equipment. A regulator is not a flow control device. It is used to control delivery pressure only.

Since there are numerous hazards associated with specialty gases—hazards that vary with the gas, the equipment used, and with the particular application—it is necessary to take the proper precautions to assure safety in high-pressure gas control.

Before performing any operation with which you are not familiar, seek the advice of an experienced individual. In addition to adhering to the safety and operating rules provided here, the user should be aware of the additional safe operating practices peculiar to each piece of equipment and each application. Consult Air Products' Technical Information Center at +1 (800) 752-1597 or your local Air Products sales office when in doubt about correct handling procedures.

Never use any regulator for gases other than those for which it is intended.

The following is applicable to pressure regulators used with flammable, oxidant, corrosive, inert, or toxic gases, when it is necessary to reduce cylinder supply pressure to a lower use pressure.

How Regulators Work

Single-Stage Regulators

High-pressure media enter the regulator through the inlet into the high-pressure chamber (see Fig. 1). When the adjusting knob is turned clockwise, it compresses the range spring and exerts a force on the diaphragm, which pushes the valve stem

open. This releases gas into the low-pressure chamber, exerting an opposing force on the diaphragm. An equilibrium is reached when the spring force on the diaphragm is equal to the opposing force of the gas in the low-pressure chamber.

In a single-stage regulator, delivery pressure increases as cylinder pressure decays, because there is less gas pressure exerted on the valve stem. Thus, frequent adjustment of the control knob is required to maintain constant delivery pressure. This does not pose a problem, however, with pipelines and liquefied gas products where inlet pressure is maintained relatively constant.

Two-Stage Regulators

A two-stage regulator functions similarly to two, single-stage regulators in series. The first stage reduces inlet pressure to a preset intermediate pressure, typically 350 to 500 psig. By adjusting the control knob, the second stage reduces the intermediate pressure to the desired delivery pressure.

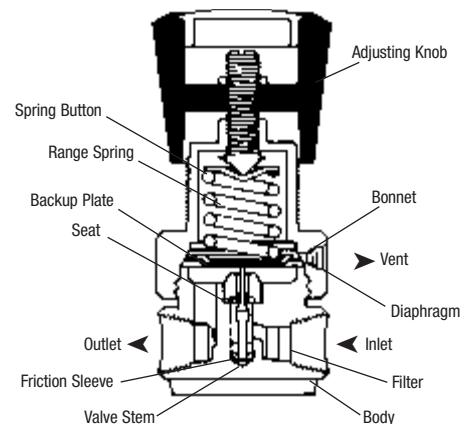

Fig. 1 Single-stage regulator.

Like the single-stage regulator, outlet pressure from the first stage of the two-stage regulator rises as cylinder pressure decreases. However, instead of passing out of the regulator, the gas flows into the second stage where the pressure is moderated. Thus, delivery pressure remains constant even as cylinder pressure decays, eliminating the need for frequent control knob adjustment.

Selecting the Proper Regulator

Line and Cylinder Regulators

Line regulators are typically point-of-use regulators serving low-pressure pipelines. They are also used in conjunction with high-pressure cylinder regulators that limit the inlet pressure to 250 to 400 psig.

Cylinder regulators are available in either single-stage or two-stage models for high-purity, general purpose, or special service applications.

High-Purity Regulators

High-purity regulators are designed and constructed to provide diffusion resistance and easy cleanup. Metal diaphragms and high-purity seats and seals minimize or eliminate outgassing and inboard diffusion.

General Purpose Regulators

General purpose regulators are designed for economy and longevity. They are recommended for noncorrosive general plant, pilot plant, and maintenance shop applications where diffusion resistance is not required.

Regulators for Oxidizers

Because oxidizers change the chemistry of fire, a material that does not burn in air may ignite or react violently in an oxidizer atmosphere. Equipment used in oxidizer service should be selected with materials of construction that minimize the probability of ignition and the risk of fire or explosion. This equipment must be cleaned to remove any contaminants such as oils or grease. Care



Fig. 2 The correct way to safety check a system.

must also be taken to eliminate any residual cleaning agents. Regulators used in oxygen service should be maintained exclusively in oxidizer service. If a regulator is used in other types of service, it may no longer meet oxidizer clean requirements.

Special Service Regulators

Special service regulators are specifically constructed for special applications including oxygen, acetylene, and fluorine service and high-pressure, ultra-high-pressure, and corrosion service.

To make your selection easier, consult Air Products' *Specialty Gas and Equipment Catalog*, which lists the proper regulator for almost every gas, pressure, and situation. Simply look up the gas or mixture for your application and you will find the appropriate regulator listed under "Recommended Equipment." CGA valve outlets are also noted for each gas and gas mixture. The regulator must be equipped with the appropriate CGA connection for the cylinder valve outlet.

Putting the Regulator into Service

1. Identify the regulator. Check the label and the inlet and outlet gauges. Ascertain that the high-pressure gauge is suitable for the pressure of the cylinder or source system.
2. Inspect the regulator. Check the regulator for evidence of damage or contamination. If there is evidence of physical damage or foreign material inside the regulator, contact your customer service representative for return or repair information.
3. Inspect the cylinder valve. Check the cylinder valve for evidence of damage or contamination. Remove any foreign material before attaching the regulator.

4. Attach the regulator. Fasten the regulator to the cylinder and tighten the inlet nut securely.
5. Close the regulator. To close the regulator, turn the adjusting knob to the full counterclockwise position. The regulator must be closed before opening the cylinder valve.

Safety-Checking the System

With the regulator adjusting knob turned fully counterclockwise, place both hands on the cylinder valve and open it slowly, allowing the pressure to rise gradually in the regulator. Stand as shown (see Fig. 2) with the cylinder valve between you and the regulator. When the high-pressure gauge indicates maximum pressure, open the cylinder valve fully.

Always close the cylinder valve when product delivery is not needed. Do not leave it open when the equipment is unattended or not operating.

Adjusting the Pressure

Turn the adjusting knob clockwise and establish the required use pressure by referring to the low-pressure gauge. Make sure that the cylinder valve is easily accessible.

Precautionary Measures

- Never exchange the discharge (low-pressure) gauge for one of lower pressure. The gauge may rupture if the adjusting knob is unintentionally turned too far.
- Check diaphragm regulators for creep (leakage of gas from the high-pressure to the low-pressure side when the adjusting knob is turned fully counterclockwise).
- Provide check valves. Back-pressure protection is needed to prevent damage to the regulator. Gas from a high-pressure system can flow back into the regulator.

Removing the Regulator from Service

1. Close the cylinder valve.
2. Vent the gas. Vent the gas in the regulator and/or system, or isolate the system, and vent the gas in the regulator by turning the

adjusting knob clockwise so that no pressure is trapped inside the regulator. If the gas is flammable, corrosive, toxic, or an oxidant, take appropriate measures to render it innocuous by employing a suitable disposal system before venting the gas to the atmosphere.

3. Close the regulator. After relieving all the gas pressure, turn the adjusting knob counterclockwise as far as it will go.
4. Disconnect low-pressure equipment. All low-pressure equipment connected to sources of high pressure should be disconnected entirely or, if not, independently vented to the atmosphere as soon as the operation is either over or shut down for an extended period of time.
5. Disconnect the regulator.
6. Protect the regulator. If the regulator is to remain out of service, protect the inlet and outlet fittings from dirt, contamination, or mechanical damage.
7. Replace the cylinder outlet seal and valve cap.

Safety Measures for Pressure-Reducing Regulators

Failure to take appropriate safety measures, including those listed below and the measures outlined in safety information provided with each product, may result in asphyxiation, fire and explosion, chemical burns, cold burns, poisoning, and system overpressurization. Any of these may result in serious injury or death.

The following general safety measures should be taken when using pressure-reducing regulators. These measures are applicable for typical applications only. They are not comprehensive. Before operation, special consideration must be given to pressure limitations, system containment, purging requirements, etc., to determine if additional safety measures are required.

1. Always keep the regulator clean.
2. Always pressurize a regulator slowly, while standing with the cylinder valve between you and the regulator.

3. Never swap gauges or inlet fittings, and never change gas service.
4. Never lubricate a regulator or use pipe dopes. This includes inlet fittings which are intended to be installed dry.
5. Never reverse flow through a regulator or rely upon it to act as a check valve. It will not perform this function.
6. Always depressurize a regulator before closing the adjusting knob and removing the regulator from the cylinder. This is especially important in two-stage regulators that can trap high-pressure gas in the first stage. Such trapped gas can vent spontaneously at any time, releasing hazardous gas or projectiles.
7. Replace your regulators before they are worn out. The operation of a compressed gas regulator to the point of failure is a false economy. Regulators should be inspected for wear and overhauled or replaced on an established schedule.
8. In the case of oxidant regulators, it is preferable to replace, rather than overhaul, the regulator. Cleaning an oxygen regulator is usually more expensive than the purchase price of a new unit. In recent years, superior fire-resistant materials have been used in many regulators. Some new models are specifically designed to resist and manage ignition, should it occur. Thus, the inherent safety of a new regulator can be a significant improvement over that of an older, rebuilt regulator. Changes in regulators through the years have included the use of new materials, such as Teflon® and Viton®, and design changes such as internal flame shields, heavy heat-sink components, minimally-sized polymer components, and substitutions of metals for polymers.

Trademarks and Registered Trademarks

- Teflon® is a registered trademark of DuPont Company.
- Viton® is a registered trademark of DuPont Company.

Emergency Response System

- Call: **+1 (800) 523-9374** (Continental U.S. and Puerto Rico)
- Call: **+1 (610) 481-7711** (Other locations)
- 24 hours a day, 7 days a week
- For assistance involving Air Products and Chemicals, Inc. gases and equipment.

Product Safety Information

- Call: **+1 (800) 245-2746**
- Fax-on-Demand
- 24 hours a day, 7 days a week
- For Material Safety Data Sheets and Safetygrams
- Enter MSDS Index No. 1000 for a complete list of available safety literature.

Technical Information Center

- Call: **+1 (800) 752-1597** (U.S.)
- Call: **+1 (610) 481-8565** (Other locations)
- Fax: **+1 (610) 481-8690**
- E-mail: **gasinfo@apci.com**
- Monday–Friday, 8:00 a.m.–5:00 p.m. EST

Information Sources

- Compressed Gas Association
1725 Jefferson Davis Highway, Suite 1004
Arlington, VA 22202-4102
Phone: +1 (703) 412-0900
- National Fire Protection Association
1 Batterymarch Park, P.O. Box 9101
Quincy, MA 02269-9101
Phone: +1 (800) 344-3555